



Product Specification

HS431-3

Features

- Equivalent Full Range Temperature Coefficient 50PPM/°C
- Temperature Compensated For Operation Over Full Rate Operating Temperature Range
- Adjustable Output Voltage
- Fast Turn-on Response
- Sink Current Capability 1 mA to 100 mA
- Low (0.27ΩTyp.) Dynamic Output Impedance
- Low Output Noise

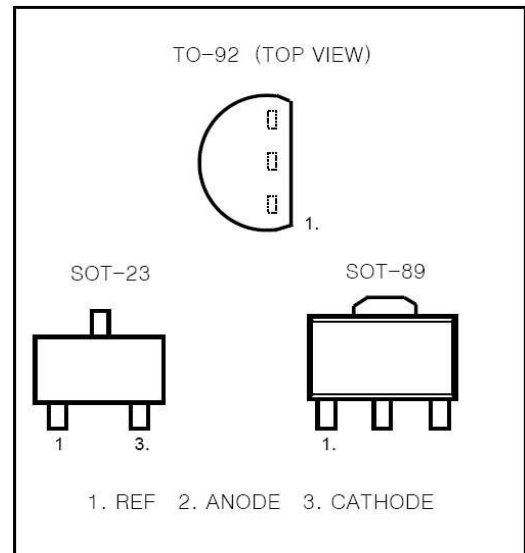

DESCRIPTION

The HS431-3 is three-terminal adjustable shunt regulator with specified thermal stability. The output voltage may be set to any value between VREF(Approx. 2.495V) and 36V with two external resistors. This device has a typical output impedance of 0.2Ω. Active output circuitry provides a very sharp turn-on characteristic, making this device excellent replacement for zener diodes in many application

FUNCTION BLOCK DIAGRAM

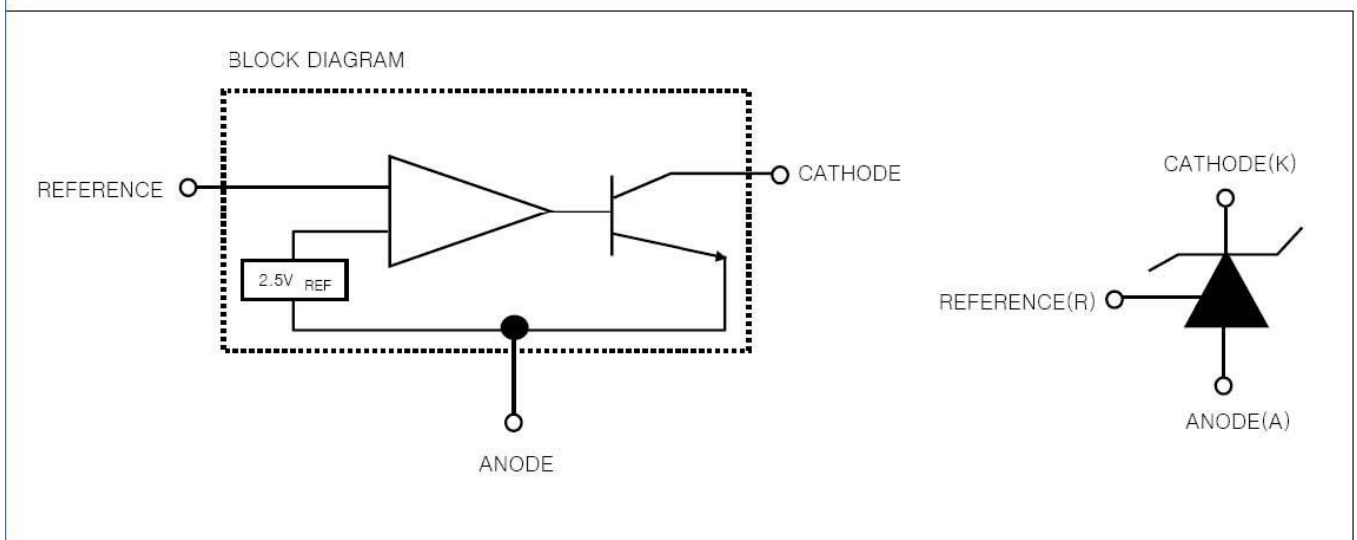



ABSOLUTE MAXIMUM RATINGS

(Full Operating Ambient Temperature Range Applies Unless Otherwise Noted)

CHARACTERISTIC	SYMBOL	RATING	UNIT
Cathode Voltage	V_{KA}	40	V
Continuous Cathode Current Range	I_{KA}	-100~+150	mA
Reference Input Current Range	I_{REF}	0.05~10	mA
Junction Temperature	T_J	150	°C
Operating Temperature	T_{OPR}	-20 ~ 85	°C
Storage Temperature	T_{SIG}	-65 ~ 150	°C
Total Power Dissipation	P_D	700	mW

ELECTRICAL CHARACTERISTICS

($T_a = 25^\circ\text{C}$, $V_{KA} = V_{REF}$, $I_K = 10\text{mA}$ unless otherwise specified)

Characteristic	Symbol	Test Condition	Min	Typ	Max	Unit
Reference Input Voltage	V_{REF}	$V_{KA} = V_{REF}$, $I_K = 10\text{mA}$	2.483	2.495	2.507	V
Deviation of Reference Input Voltage Over Full Temperature Range	$V_{REF(dev)}$	$T_{min} \leq T_a \leq T_{max}$		3	17	mV
Ratio of Change in Reference Input Voltage to the Change in Cathode Voltage	$\Delta V_{REF}/\Delta V_{KA}$	$\Delta V_{KA} = 10V - V_{REF}$ $\Delta V_{KA} = 36V - 10V$	-0.4	0.0	2.7	mV/V
Reference Input Current	I_{REF}	$R_1 = 10K\Omega$, $R_2 = \infty$		1.8	4	μA
Deviation of Reference Input Current Over Full Temperature Range	$I_{REF(dev)}$	$R_1 = 10K\Omega$, $R_2 = \infty$		0.4	1.2	μA
Minimum Cathode Current for Regulation	$I_{K(min)}$			0.25	0.5	mA
Off-State Cathode Current	$I_{K(off)}$	$V_{KA} = 40\text{V}$, $V_{REF} = 0$		0.17	0.9	μA
Dynamic Impedance	Z_{CA}	$I_K = 10\text{mA}$ to 100mA , $f \leq 1.0\text{KHz}$		0.27	0.5	Ω

Fig. 1 Test Circuit for $V_{KA} = V_{REF}$

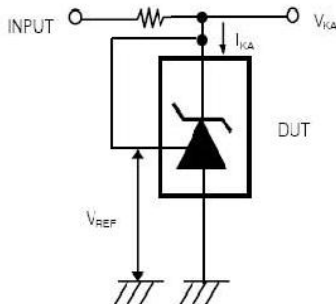

Fig. 2 Test Circuit for $V_{KA} \geq V_{REF}$

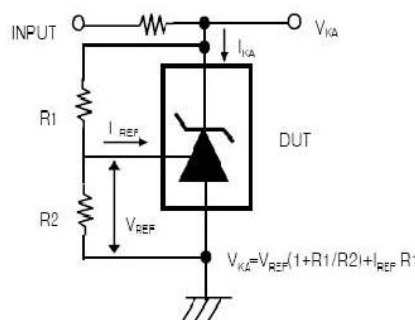
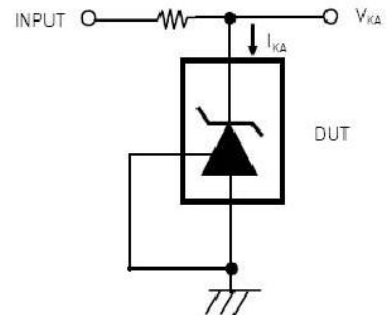
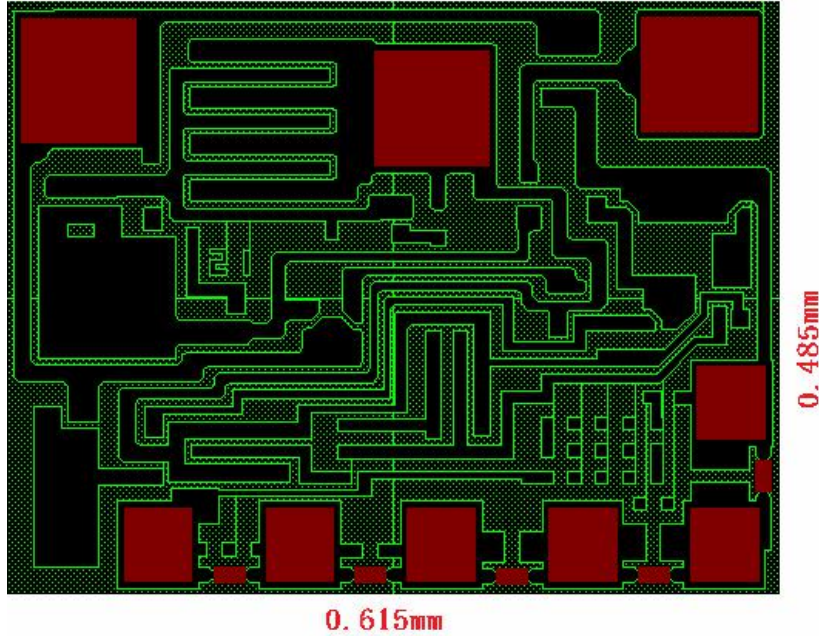

Fig. 3 Test Circuit for $I_{KA} (off)$





PAD LAYOUT



BONDING DIAGRAM

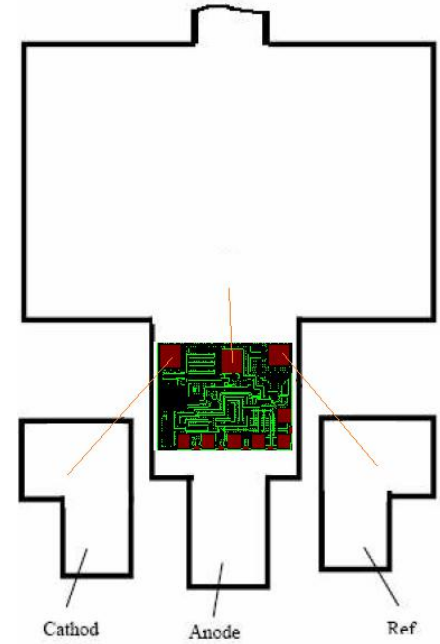

PAD LOCATION

PAD NAME	DESCRIPTION	X	Y
VCC	CATHODE	58	373
GND	ANODE	310	353
VREF	REFERENCE	500	377

PHYSICAL CHARACTERISTIC

Wafer dia	150mm (6")
Wafer width	300±20 um
Scribe width	60um
Backside metallization	Without metallization