



HS1464 150KHz 2A PWM Buck DC/DC Converter

General Description

The HS1464 is a monolithic IC designed for a step-down DC/DC converter, and own the ability of driving a 2A load without additional transistor. It saves board space. The external shutdown function can be controlled by logic level and then come into standby mode. The internal compensation makes feedback control having good line and load regulation without external design. Regarding protected function, thermal shutdown is to prevent over temperature operating from damage, and current limit is against over current operating of the output switch. If current limit function occurs

and V_{FB} is down below 0.5V, the switching frequency will be reduced. The HS1464 operates at a switching frequency of 150KHz thus allow smaller sized filter components than what would be needed with lower frequency switching regulators. Other features include a guaranteed $\pm 4\%$ tolerance on output voltage under specified input voltage and output load conditions, and $\pm 15\%$ on the oscillator frequency. The output version included fixed 3.3V, 5V, 12V, and an adjustable type. The chips are available in a standard 8-lead SOP8 package.

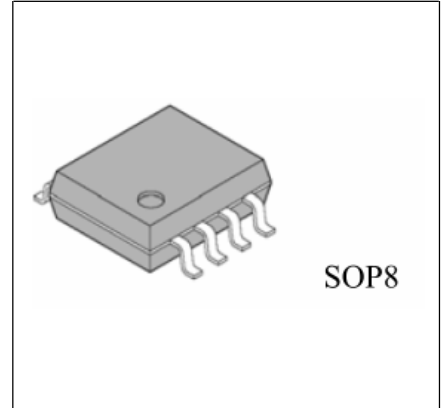

Features

- 3.3V, 5V, 12V and Adjustable Output Version
- Output Adjustable Voltage From 1.23V to 37V
- Fixed 150KHz Switching Frequency
- Voltage Mode Non-synchronous PWM Control
- Thermal-Shutdown and Current-Limit Protection
- ON/OFF Shutdown Control Input
- Wide 4.5V to 40V Input Voltage Range
- Output Load Current: 2A
- Low Power Standby Mode
- Built-in Switching Transistor on Chip

Application

- Simple High-Efficiency Step-down Regulator
- On-card Switching Regulators
- Positive to Negative Converter

Pin Configuration

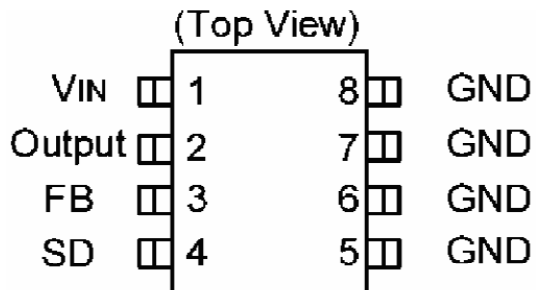

Pin Descriptions

Name	Description
V _{IN}	Supply Voltage Input
Output	Power Switching Output
GND	Ground
FB	Output Voltage Feedback Control
SD	ON/OFF Shutdown

Block Diagram

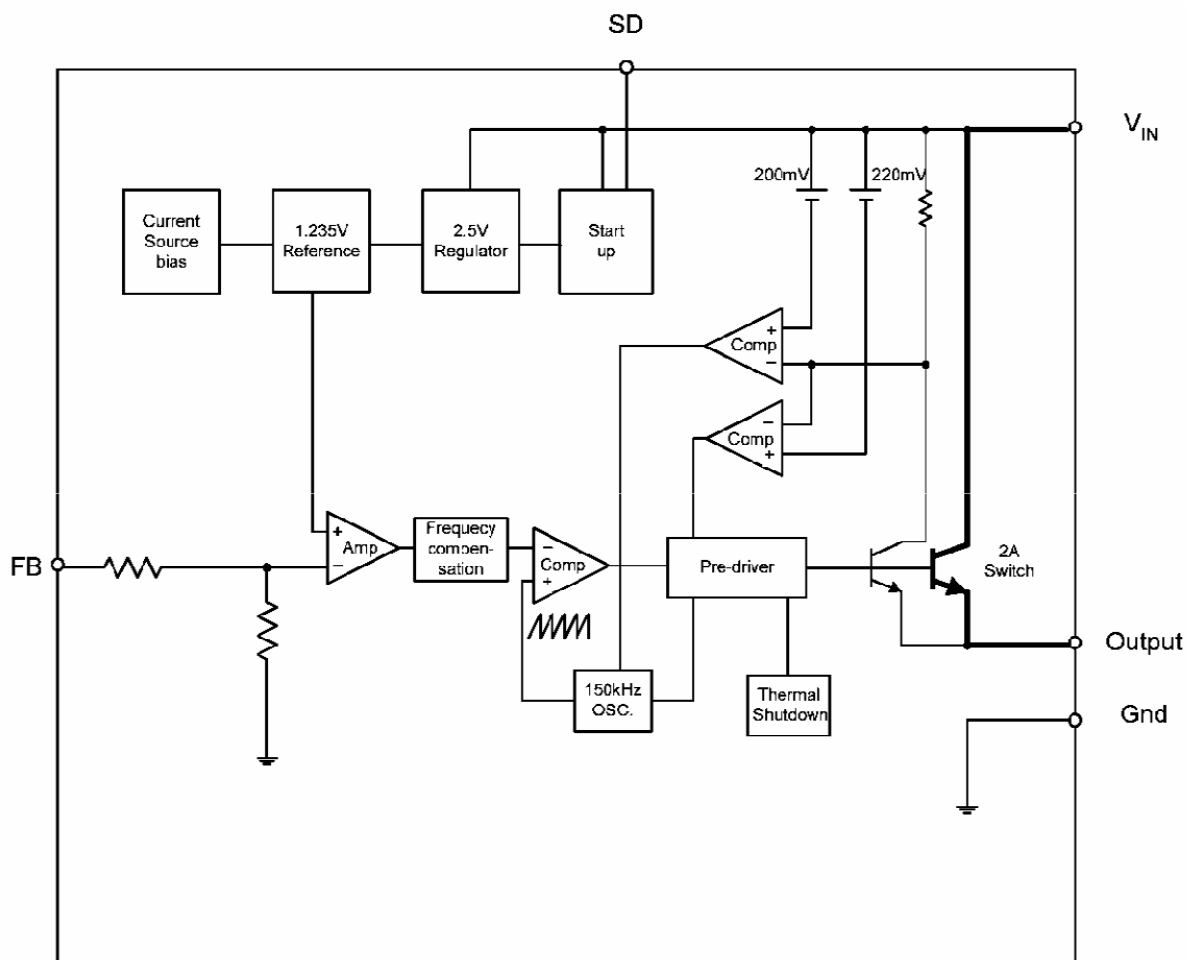

Absolute Maximum Ratings

Characteristics	Symbol	Value	Unit
Supply Voltage	V _{IN}	+40	V
ON/OFF pin input voltage	V _{SD}	-0.3 ~ V _{IN}	V
Feedback pin voltage	V _{FB}	-0.3 ~ V _{IN}	V
Output voltage to ground	V _{OUT}	-1	V
Power dissipation	PD	Internally limited	W
Storage temperature	T _{stg}	-65 ~ +150	°C
Operating temperature	T _{opr}	-40 ~ +125	°C
Operating voltage	V _{OP}	+4.5 ~ +40	V

Electrical Characteristics

(Refer to the test circuit, V_{IN}=12V for 3.3V, 5V, adjustable version and V_{IN}=24V for the 12V version, I_{LOAD}=0.5A)

Characteristics	Symbol	Test Conditions	Min	Typ	Max	Unit
Feedback Bias Current	I _{FB}	V _{FB} =1.3V (Adjustable version only)		50	100	nA
Oscillator Frequency	F _{osc}		127	150	173	kHz
Saturation Voltage	V _{SAT}	I _{OUT} =2A, No outside circuit V _{FB} =0V force driver on		1.2	1.5	V
Max. Duty Cycle(ON)	DC	V _{FB} =0V force driver on	93	98		%
Min. Duty Cycle(OFF)		V _{FB} =12V force driver off		0		
Current Limit	I _{CL}	Peak current, No outside circuit V _{FB} =0V force driver on	3.0	4.0		A
Output Leakage Current (Output=0)	I _L	No outside circuit V _{FB} =12V force driver off			2	mA
Output Leakage Current (Output=-1)		V _{IN} =40V		5	20	mA
Quiescent Current	I _Q	V _{FB} =12V force driver off		5	10	mA
Standby Quiescent Current	I _{STBY}	ON/OFF pin=5V V _{IN} =40V		50	200	μA
ON/OFF pin Logic Input Threshold Voltage	V _{IL}	Low(regulator ON)			0.6	V
	V _{IH}	High(regulator OFF)	2.0			
ON/OFF pin Logic Input Current	I _H	V _{LOGIC} =5.0V(OFF)		12	30	μA
ON/OFF pin Input Current	I _L	V _{LOGIC} =0.5V(ON)		0	10	
Thermal Resistance	Θ _{JC}	Junction to case		15		°C/W
Thermal Resistance with Copper Area of Approximately 3 in ²	Θ _{JA}	Junction to ambient		70		°C/W

Continue:



HS1464

Characteristics	Symbol	Test Conditions	Min	Typ	Max	Unit
HS1464-ADJE1						
Output Feedback	V_{FB}	$4.5V \leq V_{IN} \leq 40V$ $0.2A \leq I_{LOAD} \leq 2A$ V_{OUT} programmed for 3V	1.193	1.230	1.267	V
Efficiency	η	$V_{IN}=12V, I_{LOAD}=2A$		74		%
HS1464-3.3E1						
Output Voltage	V_{OUT}	$4.75V \leq V_{IN} \leq 40V$ $0.2A \leq I_{LOAD} \leq 2A$	3.168	3.300	3.432	V
Efficiency	η	$V_{IN}=12V, I_{LOAD}=2A$		76		%
HS1464-5.0E1						
Output Voltage	V_{OUT}	$7V < V_{IN} < 40V$ $0.2A \leq I_{LOAD} \leq 2A$	4.80	5.00	5.20	V
Efficiency	η	$V_{IN}=12V, I_{LOAD}=2A$		83		%
HS1464-12E1						
Output Voltage	V_{OUT}	$15V \leq V_{IN} \leq 40V$ $0.2A \leq I_{LOAD} \leq 2A$	11.52	12.00	12.48	V
Efficiency	η	$V_{IN}=25V, I_{LOAD}=2A$		90		%

Function Description

Pin Function + V_{IN}

This is the positive input supply for the IC switching regulator. A suitable input bypass capacitor must be presented at this pin to minimize voltage transients and to supply the switching currents needed by the regulator.

Ground

Circuit ground.

Output

Internal switch. The voltage at this pin switches between $(+V_{IN} - V_{SAT})$ and approximately $-0.5V$, with a duty cycle of approximately V_{OUT} / V_{IN} . To minimize coupling to sensitive circuitry, the PC board copper area connected to this pin should be minimized.

Feedback

Senses the regulated output voltage to complete the feedback loop.

SD

Allows the switching regulator circuit to be shutdown using logic level signals thus dropping the total input supply current to approximately 150uA. Pulling this pin below a threshold voltage of approximately 1.3V turns the regulator on, and pulling this pin above 1.3V (up to a maximum of 18V) shuts the regulator down. If this shutdown feature is not needed, the SD pin can be wired to the ground pin.

Thermal Considerations

The SOP8 package needs a heat sink under most conditions. The size of the heatsink depends on the input voltage, the output voltage, the load current and the ambient temperature. The HS1464 junction temperature rises above ambient temperature for a 2A load and different input and output voltages. The data for these curves was taken with the HS1464 (SOP8 package) operating as a buck-switching regulator in an ambient temperature of 25 °C (still air). These temperature increments are all approximate and are affected by many factors. Higher ambient temperatures requires more heat sinker.

For the best thermal performance, wide copper traces and generous amounts of printed circuit board copper should be used in the board layout. (One exception is the output (switch) pin, which should not have large areas of copper.) Large areas of copper provide the best transfer of heat (lower thermal resistance) to the surrounding air, and moving air lowers the thermal resistance even further.

Package thermal resistance and junction temperature increments are all approximate. The increments are affected by a lot of factors. Some of these factors include board size, shape, thickness, position, location, and even board temperature. Other factors are, trace width, total printed circuit copper area, copper thickness, single or double-sided, multi-layer board and the amount of solder on the board.

The effectiveness of the PC board to dissipate heat also depends on the size, quantity and spacing of other components on the board, as well as whether the surrounding air is still or moving. Furthermore, some of these components such as the catch diode will add heat to the PC board and the heat can vary as the input voltage changes. For the inductor, depending on the physical size, type of core material and the DC resistance, it could either act as a heat sink taking heat away from the board, or it could add heat to the board.

Application Circuit

Fixed Type Circuit

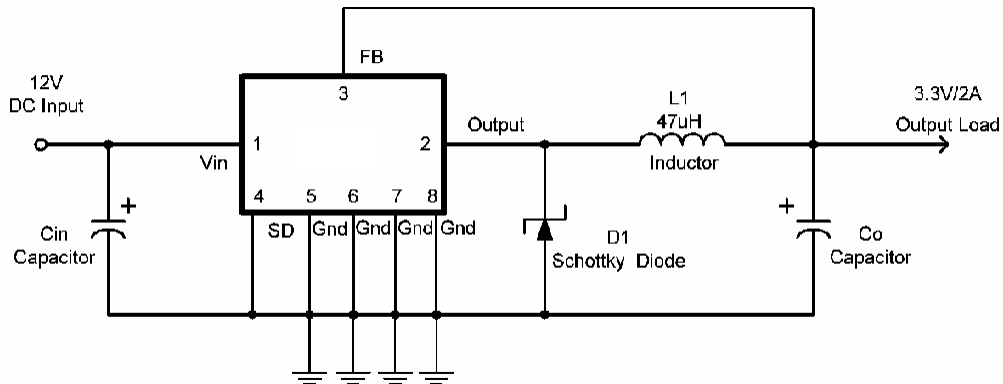

Adjustable Type Circuit

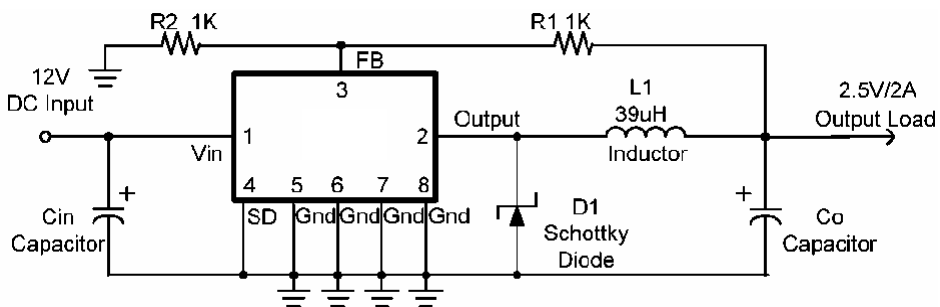

$$V_{out} = V_{FB} \times \left(1 + \frac{R1}{R2}\right)$$

$$V_{FB} = 1.23V$$

$$R2 = 1K \sim 3K$$

Delay Start Circuit

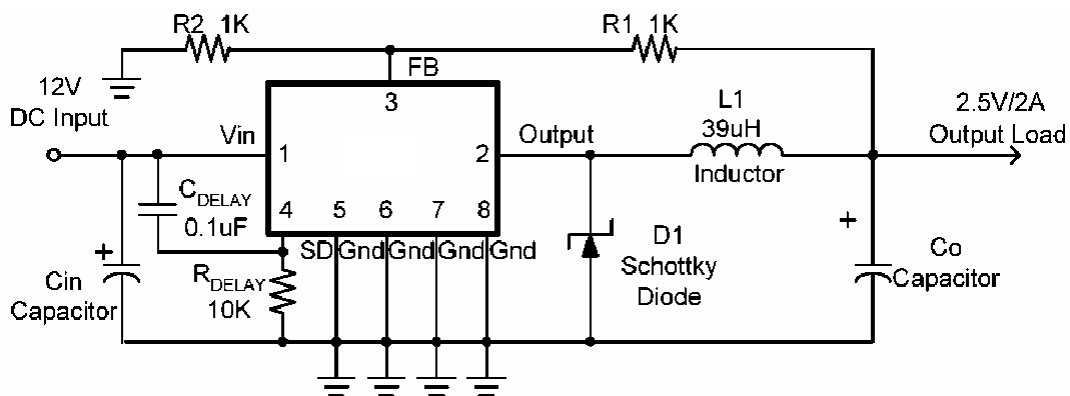

Outline Drawing

