

HS122 TRANSISTOR (NPN)

FEATURES

- High DC Current Gain
- Electrically Similar to Popular HS122
- Built-in a Damper Diode at E-C

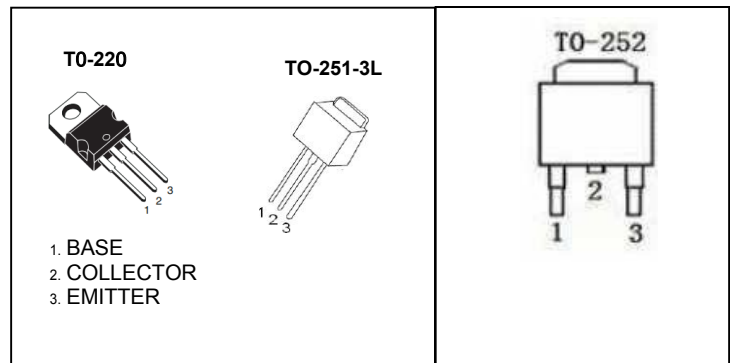

MAXIMUM RATINGS (T_a=25°C unless otherwise noted)

Symbol	Parameter	Value	Unit
V _{CB0}	Collector-Base Voltage	100	V
V _{CEO}	Collector-Emitter Voltage	100	V
V _{EBO}	Emitter-Base Voltage	5	V
I _c	Collector Current -Continuous	8	A
P _c	Collector Dissipation	1.5	W
T _J , T _{stg}	Junction and Storage Temperature	-55-150	°C

ELECTRICAL CHARACTERISTICS (T_a=25 °C unless otherwise specified)

Parameter	Symbol	Test conditions	Min	Typ	Max	Unit
Collector-base breakdown voltage	V _{(BR)CBO}	I _c =1mA, I _E =0	100			V
Collector-emitter breakdown voltage	V _{(BR)CEO}	I _c =30mA, I _B =0	100			V
Emitter-base breakdown voltage	V _{(BR)EBO}	I _E =3mA, I _C =0	5			V
Collector cut-off current	I _{CBO}	V _{CB} =100V, I _E =0			10	μA
Collector-emitter cut-off current	I _{CEO}	V _{CE} =50V, I _E =0			10	μA
Emitter cut-off current	I _{EBO}	V _{EB} =5V, I _C =0			2	mA
DC current gain	h _{FE(2)}	V _{CE} =4V, I _C =4A	1000		12000	
	h _{FE(3)}	V _{CE} =4V, I _C =8A	100			
Collector-emitter saturation voltage	V _{CE(sat)1}	I _C =4A, I _B =16mA			2	V
	V _{CE(sat)2}	I _C =8A, I _B =80mA			4	V
Base-emitter saturation voltage	V _{BE(sat)}	I _C =8A, I _B =80mA			4.5	V
Base-emitter voltage*	V _{BE}	V _{CE} =4V, I _C =4A			2.8	V
Collector output capacitance	C _{ob}	V _{CB} =10V, I _E =0, f=0.1MHz			200	pF

Typical Characteristics

HS122

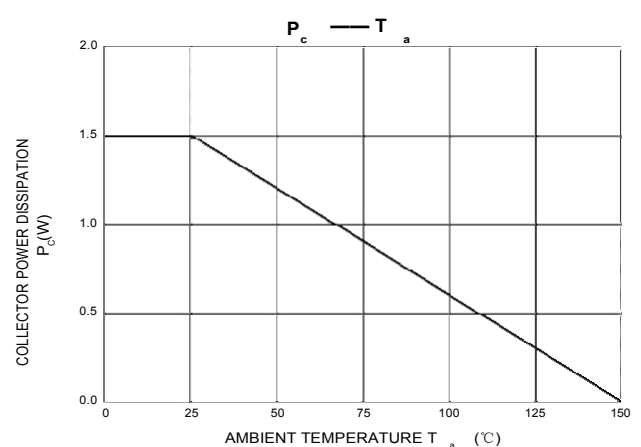
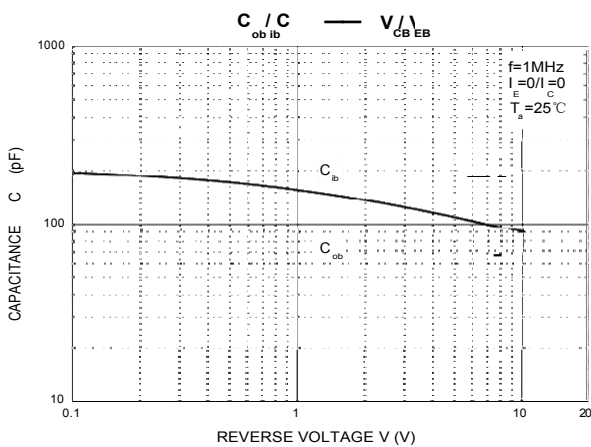
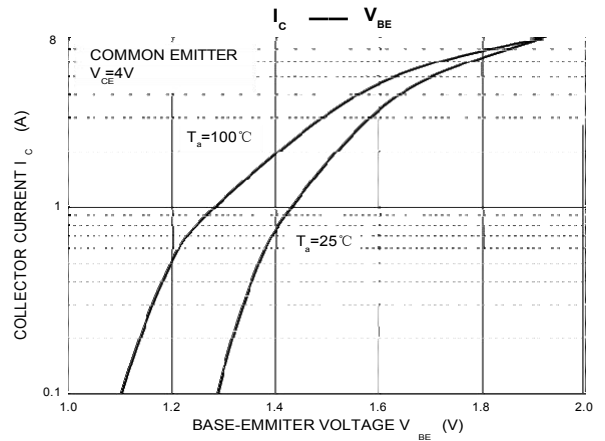
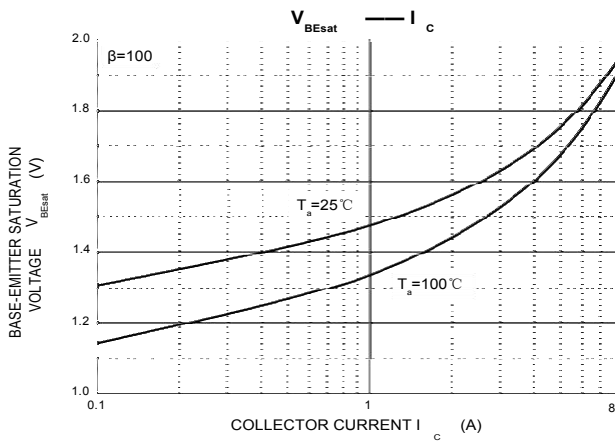
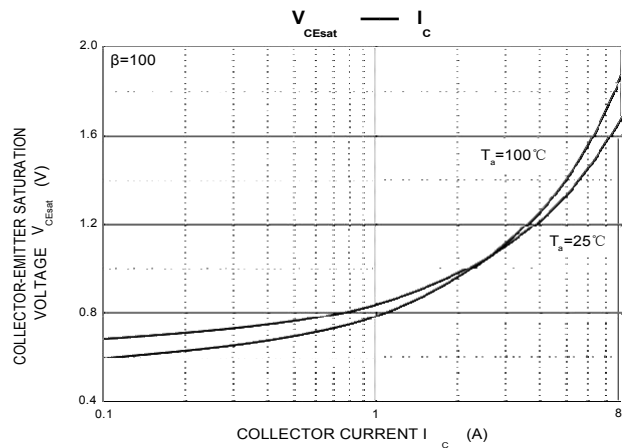
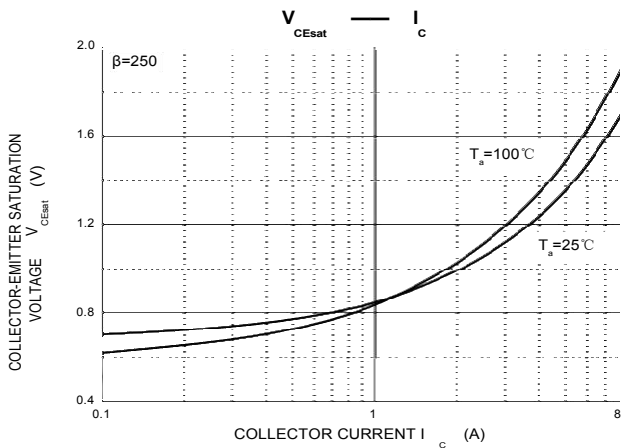
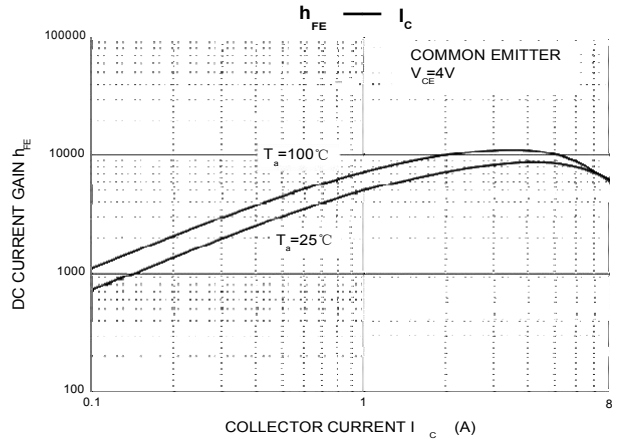
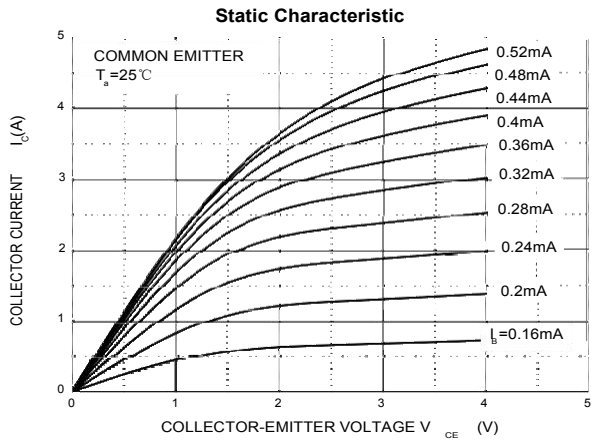

TO-251-3L Package Outline Dimensions

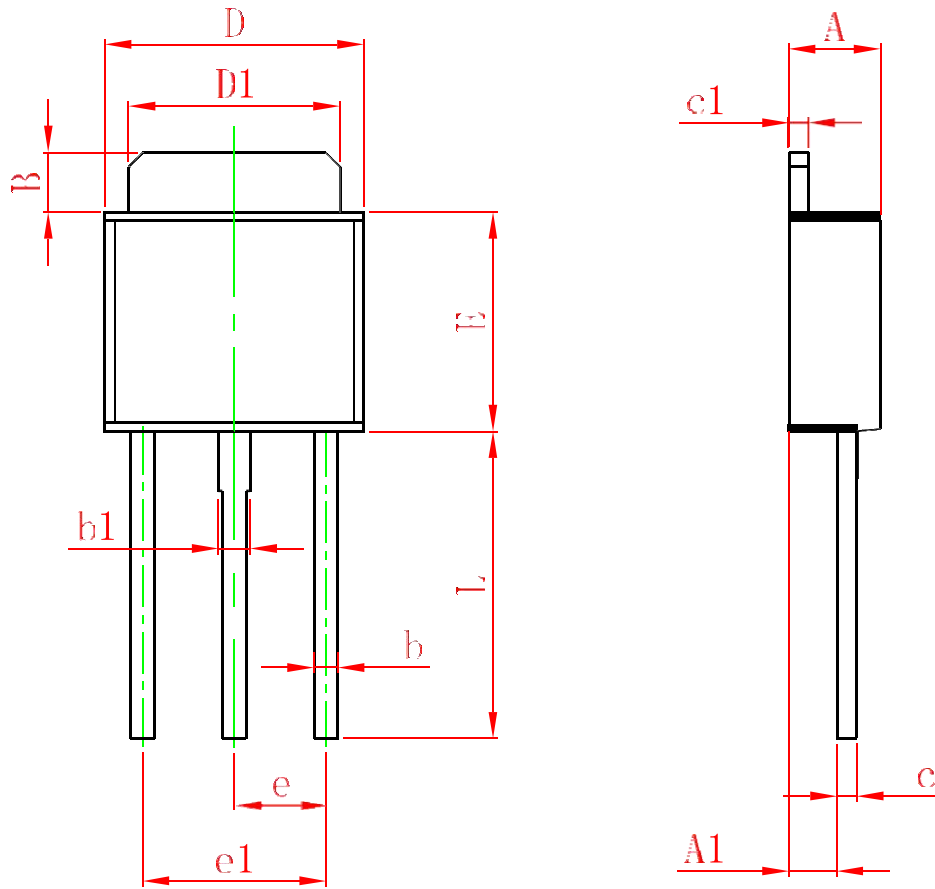

Symbol	Dimensions In Millimeters		Dimensions In Inches	
	Min.	Max.	Min.	Max.
A	2.200	2.400	0.087	0.094
A1	1.050	1.350	0.042	0.054
B	1.350	1.650	0.053	0.065
b	0.500	0.700	0.020	0.028
b1	0.700	0.900	0.028	0.035
c	0.430	0.580	0.017	0.023
c1	0.430	0.580	0.017	0.023
D	6.350	6.650	0.250	0.262
D1	5.200	5.400	0.205	0.213
E	5.400	5.700	0.213	0.224
e	2.300 TYP.		0.091 TYP.	
e1	4.500	4.700	0.177	0.185
L	7.500	7.900	0.295	0.311

TO-252-2L Package Outline Dimensions

TO-252-2L PACKAGE OUTLINE DIMENSIONS

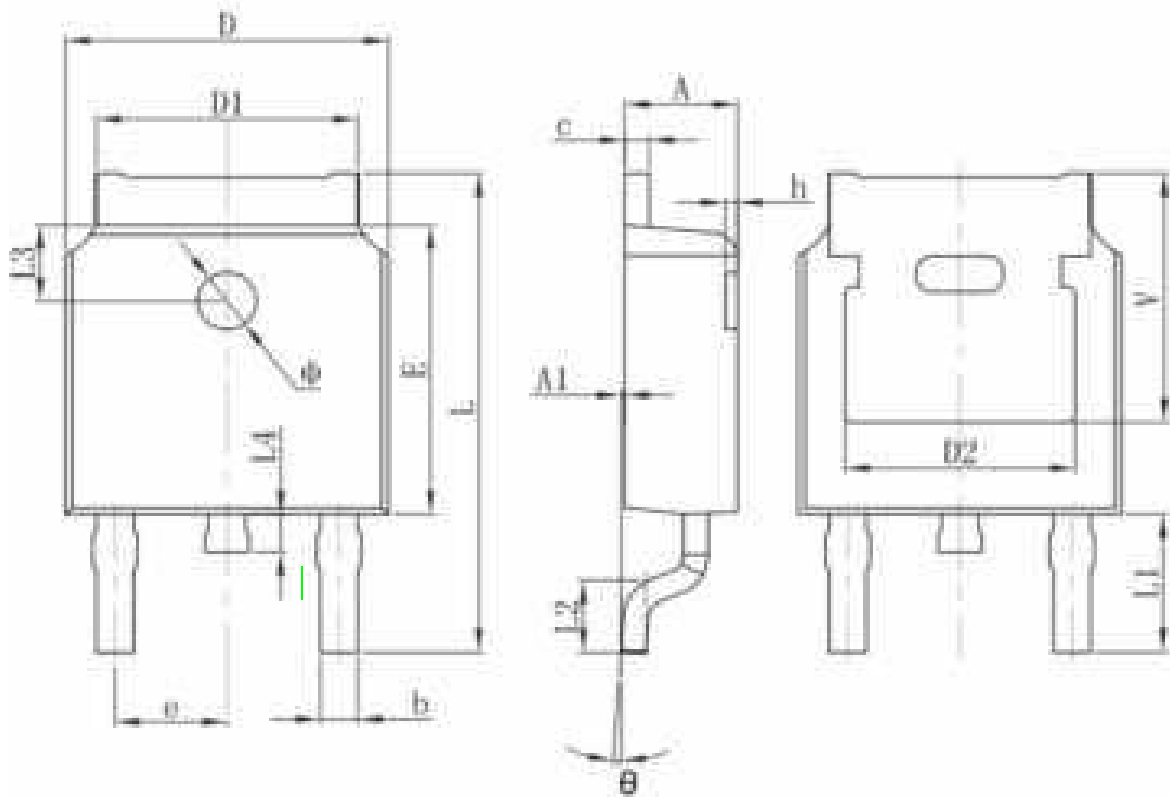

Symbol	Dimensions in Millimeters		Dimensions in Inches	
	Min.	Max.	Min.	Max.
A	2.200	2.400	0.087	0.094
A1	0.000	0.127	0.000	0.005
b	0.860	0.860	0.026	0.034
c	0.460	0.580	0.018	0.023
D	6.500	6.700	0.256	0.264
D1	5.100	5.460	0.201	0.215
D2	4.830 REF.		0.190 REF.	
E	6.000	6.200	0.236	0.244
e	2.186	2.386	0.086	0.094
L	9.800	10.400	0.386	0.409
L1	2.900 REF.		0.114 REF.	
L2	1.400	1.700	0.055	0.067
L3	1.600 REF.		0.063 REF.	
L4	0.600	1.000	0.024	0.039
phi	1.100	1.300	0.043	0.051
theta	0°	8°	0°	8°
h	0.000	0.300	0.000	0.012
V	5.350 REF.		0.211 REF.	